

Envirofilter™



A high-performance in-line system filter to remove all types of contaminants from central heating system water.

In-line system filters are used to keep central heating systems in good condition by preventing damaging debris accumulating within the system water. The build-up of sludge in radiators not only reduces the overall efficiency of a heating system itself, but can also cause permanent damage to the boiler's heat exchanger.

The Firebird Envirofilter™ combines hydrocyclonic action with powerful Neodymium magnetic assemblies, to remove magnetic and non-magnetic contaminants from system water and contain them safely within the filter. It fits onto vertical and horizontal pipework, can be cleaned in minutes and does not restrict flow in any way. If properly serviced and maintained, installing a Firebird Envirofilter™ can maintain heating system efficiency and reduce the damage caused by any contaminants.

- ✓ Hydrocyclonic and magnetic in-line filter
- ✓ Unique action, removes magnetic and non-magnetic contaminants
- ✓ Fits vertical and horizontal pipework
- ✓ Compatible with all Firebird boilers
- ✓ Cleaned in minutes without removal or disassembly
- ✓ Will not block or restrict flow
- ✓ All valves and fittings included
- ✓ Pack includes cleaner and inhibitor
- ✓ Available with 22mm or 28mm fittings
- ✓ Complies with Firebird warranty criteria
- ✓ 2-year warranty

As with all magnetic products, if you have an implanted cardiac device extra caution should be taken at all times when handling any Firebird Envirofilter.



T: 01752 691177 E: sales@firebird.uk.com
www.firebird.uk.com

SUPERIOR HEATING SOLUTIONS
SINCE 1980

**Firebird®**
Central to Heating

Application

The Firebird Envirofilter™ can be connected directly onto 22mm and 28mm pipework using the connectors and valve fittings provided. The Firebird Envirofilter™ is supplied ready to install into vertical pipework with system water flowing upwards. Detailed installation instructions are included within the pack.

Product Specifications

Maximum temperature	100°C
Maximum working pressure	3 bar
Maximum flow rate	50 L/min
Magnetic characteristics	9000 Gauss Neodymium magnet assembly
Body material	Glass fibre reinforced nylon plastic

Dimensions & Weight

Height	288 mm or 11.34"
Width	157 mm or 6.18"
Depth	109 mm or 4.29"
Envirofilter™ with 22 mm valves	1.53 kg
Envirofilter™ with 28 mm valves	1.76 kg

Firebird Envirofilter™

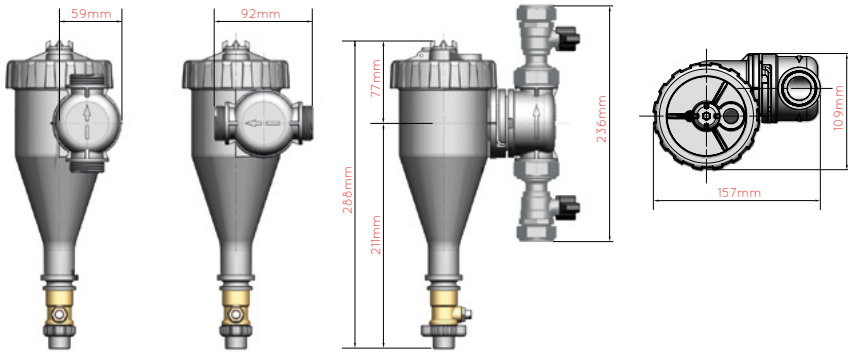

Cleaning Guide



1. Close inlet and outlet valves.



2. Remove magnet.

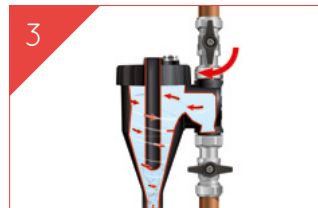

3. Open outlet and drain valves.



4. Close drain valve, replace magnet and open inlet valve.

Inlet/Outlet Orientation Guide

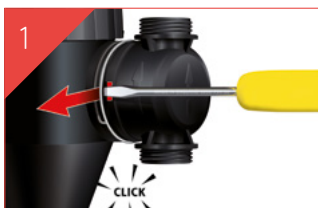

1. Using a flat end screwdriver in the recess shown, gently lever the locking clip into the 'unlock' position.



2. Pull the inlet/outlet port approximately 3 mm away from the body to allow rotation to the required position.



3. Push the inlet/outlet port back towards the body of the unit to prevent further rotation.



4. Push the locking clip securely back into the 'lock' position.